

**ECO
RIGHT**

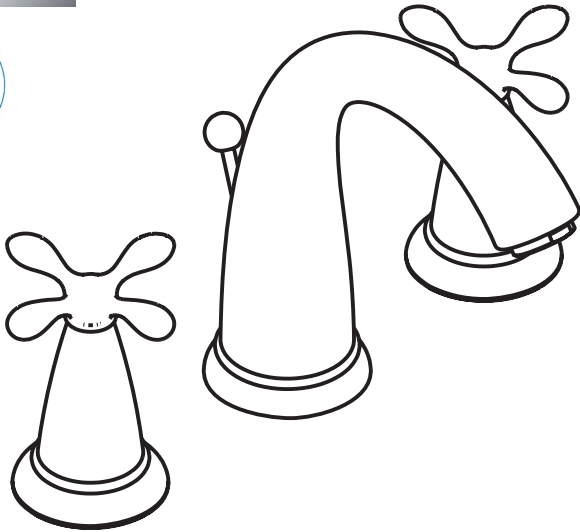

Product Features

- Solid brass
- Cross handles
- 90° Ceramic cartridges
- Flexible connection hoses
- Includes pop-up drain
- 1.5 gpm

Code Compliance

This unit meets or exceeds the following:

- ASME A112.18.1
- CSA B125.1
- Listed by IAPMO
- WaterSense certified
- Approved for use in Massachusetts

Available Finishes

Chrome

17104001

Oil Rubbed Bronze

17104621

Brushed Nickel

17104821

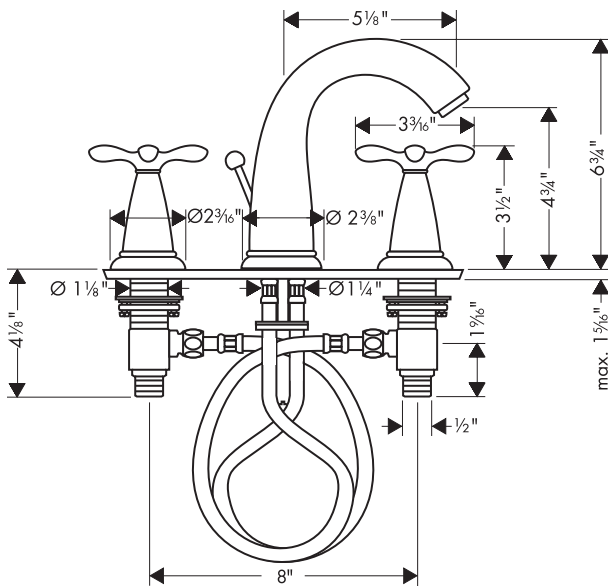

The measurements shown are for reference only.

Products and specifications shown are subject to change without notice.

Specification sheet revised 5/2009