

Axor Carlton Widespread Lav Set

17133XX1

ECO
RIGHT

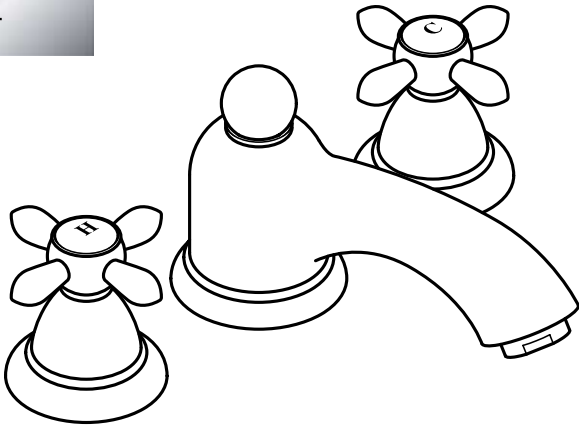

Product Features

- Cross handles
- Flexible connection hoses
- 90° Ceramic cartridges
- Includes pop-up drain
- 1.5 gpm

Code Compliance

This unit meets or exceeds the following:

- ASME A112.18.1
- CSA B125.1
- Listed by IAPMO
- Approved for use in Massachusetts

Available Finishes

Chrome	17133001
Oil Rubbed Bronze	17133621
Brushed Nickel	17133821
Polished Nickel	17133831

Installation Notes

- Requires 1/2" supply lines

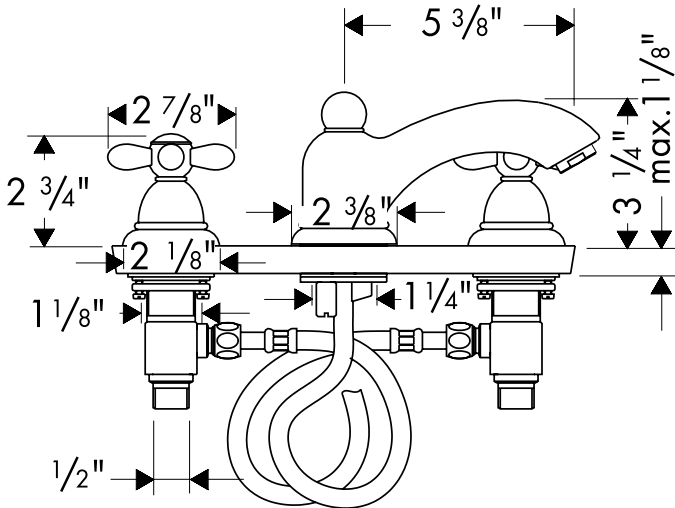

The measurements shown are for reference only.

Products and specifications shown are subject to change without notice.

Specification sheet revised 03/2009

AXOR[®]
hansgrohe